

# Weld-In I.F.S. Kits

As Shown  
**\$3,630**



1958 Rolls Royce  
"Derelict" by ICON

## I.F.S. WELD-IN KIT, COMPLETE

I.F.S. Weld-In Crossmember and Control Arms.....	<b>\$1,770.00</b>
<i>(basic kit as shown at right)</i>	
Tie Rod Ends.....	70.00
Power Rack.....	650.00
Strange Shocks w/Springs.....	560.00
I.F.S. Sway Bar Kit.....	250.00
Spindles.....	380.00
TOTAL.....	<b>3,680.00</b>
Package Discount.....	-50.00
<b>Package Price.....</b>	<b>\$3,630.00</b>

As Shown  
**\$1,770**

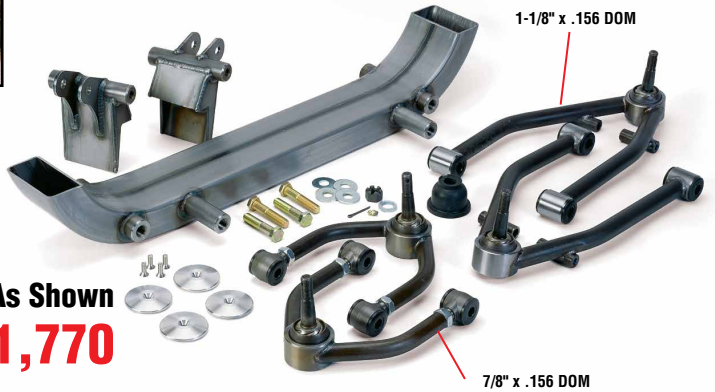

## AME Weld-In Crossmembers Available In Six Popular Widths

Art Morrison Enterprises offers weld-in front crossmembers in a variety of widths. To determine which is best suited to your car or truck, you'll need to determine the distance

from the outside of the right frame rail to the outside of the left frame rail. This distance is shown on the left side of the adjacent chart. On the right side of the chart you'll see the track

width for the corresponding assembly. Track width is determined from hub-to-hub. Please also consider wheel size and offset when determining width.

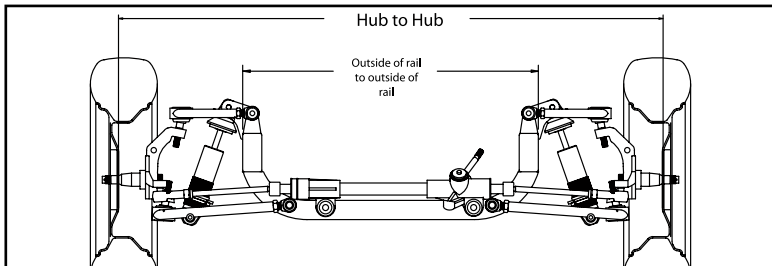

Based on 4" High Frame	
Frame O/S to O/S	Track Width
22"	48"
28"	54"
28"	57"
31"	57"
31"	60"
34"	62"

[www.artmorrison.com](http://www.artmorrison.com)

**WARNING:** Cancer Reproductive Harm  
[www.P65Warnings.ca.gov](http://www.P65Warnings.ca.gov)



**MORRISON**  
ART MORRISON ENTERPRISES  
AM